

i.materialise

Table lamps made easy

Manual

i.materialise Table Lamp - V1

Contents

Introduction - 3

Design Kit - 6

Example - 12

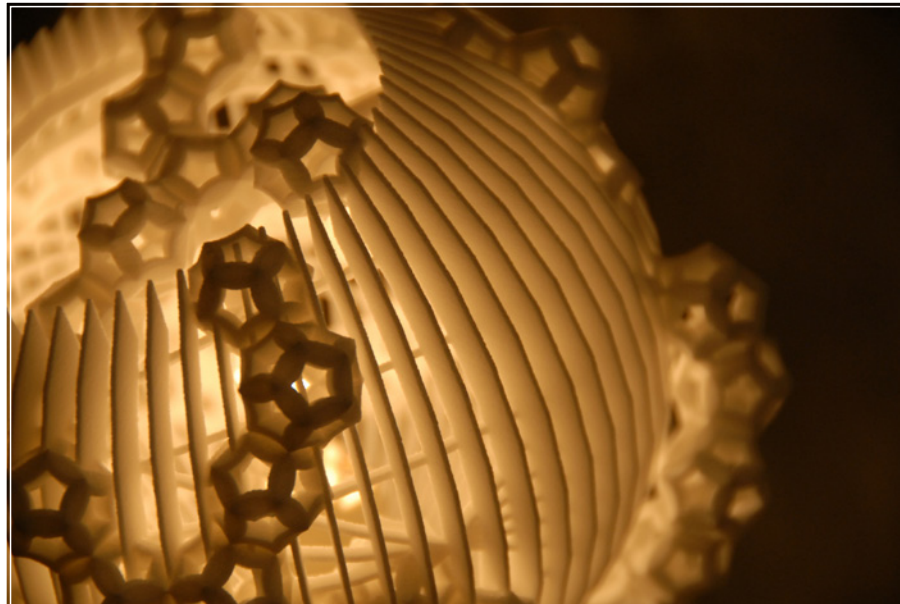

Design by Hans Palacios

i.materialise

i.materialise is a 3D printing service for everybody with an eye for design and a head full of ideas.

We want you to focus on the creation of designs –made by you– that add value to people's lives, while we do the manufacturing.

We want to be the power behind your design.



Design by Zach Hines & Oliver Dibrován



Design by Patricia.Lopes

Most people buy a lamp, extraordinary people design

Perhaps you have never designed a lamp before, but you are experienced in using 3D modeling software like Rhino, 3D Studio Max, Google SketchUp or Blender. We will help you to turn your idea into a one-of-a-kind table lamp. Let's get you on the right track.

*There's something special about physically holding
a design you've spent so many hours on.*

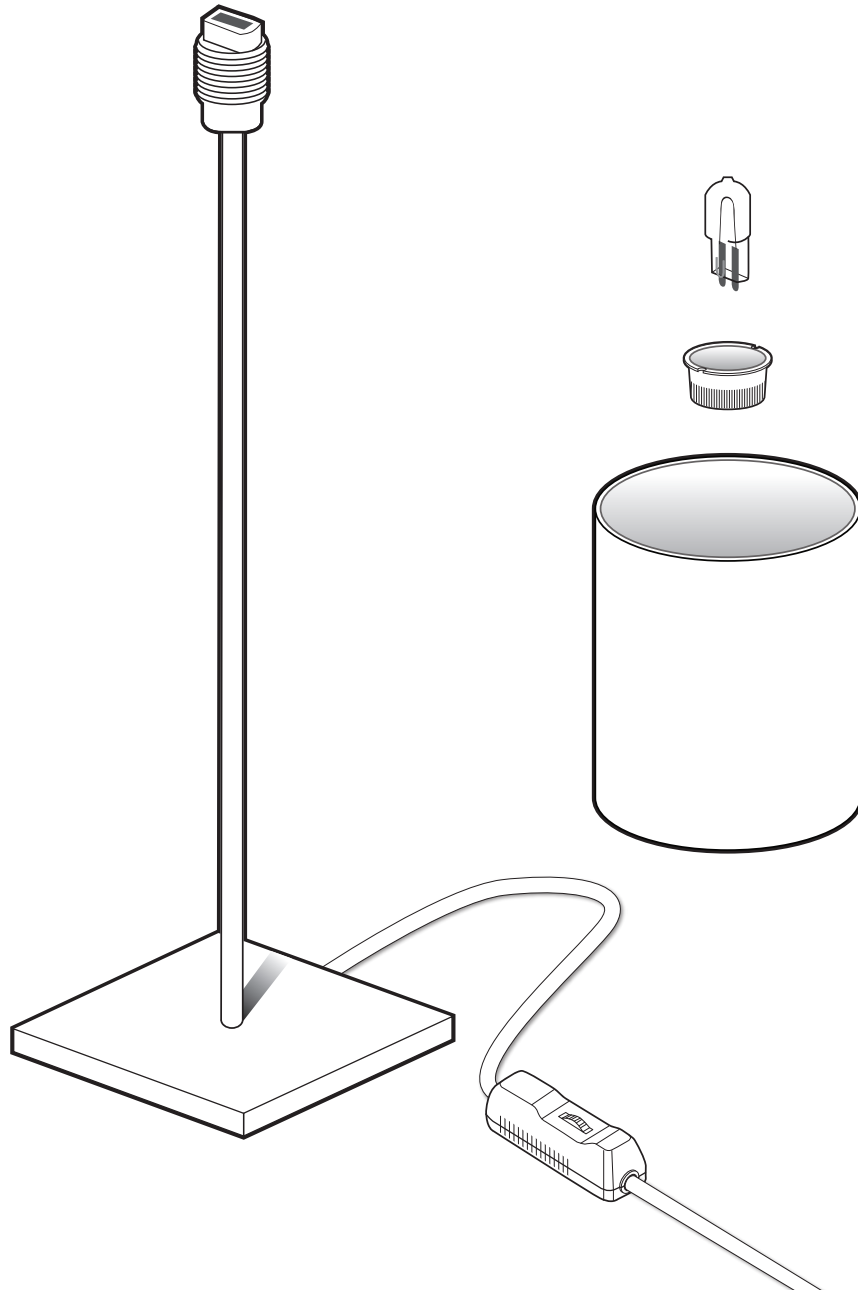

How does it work?

It's simple.

We offer you a building volume with fixed dimensions for your lamp shade. With our design kit, you can prepare your file for production.

We'll offer you the following items: (from left to right)

a lamp base with a dimmer

a 3d printed lamp shade with a glued G9 fitting ring

a bulb

a small leaflet explaining the installation, safety, and usage guidelines

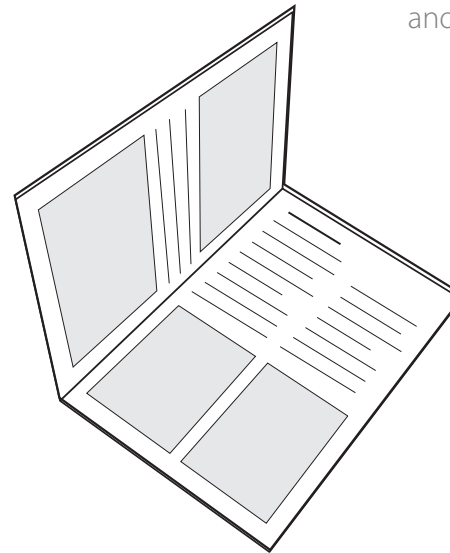

Download the Design kit

On the website you can select the software program you want to design in. In these files you'll find the different layers with aids and guides, which will help you make your design printable.

You can choose from the following file types:

Google SketchUp



.skp

Rhino



.3dm

Blender



.blend

3ds Max



.3ds

Wavefront

.obj

TIP

Once you've selected and downloaded the kit, you can get started. However, it's best to read through the manual and get to know the do's and don'ts.

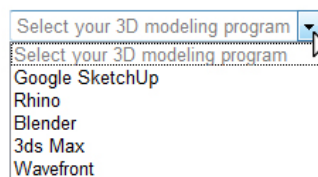

DOWNLOAD ↑

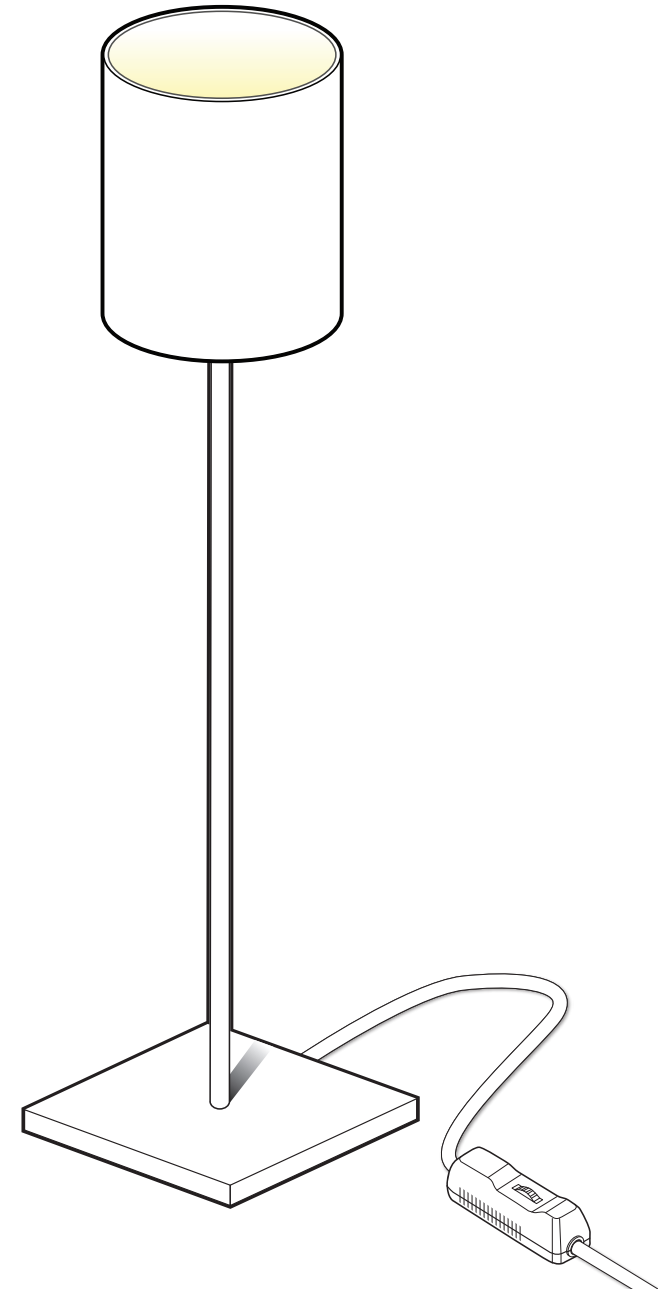

Content Design kit

Open the design kit in your 3D modeling program and you will find:

The base

The Spherical safety zone

The lamp fitting

A reference shade

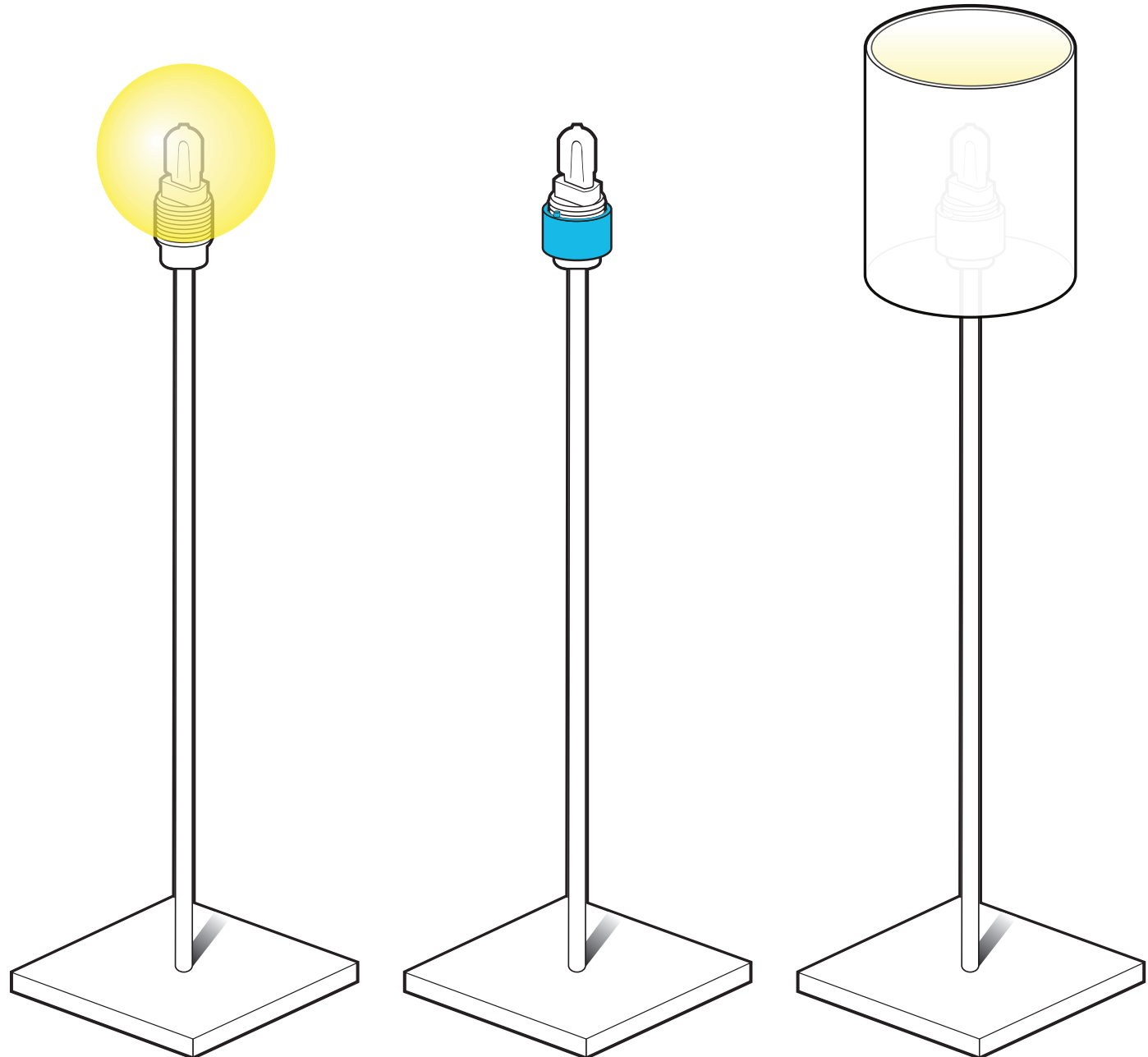

Step 1 - Size lampshade

Bounding box

With the fixed price of the lamp comes a bounding box and your design has to fit inside of this box. So, it's a good to take this into account when starting your design in order to avoid having to rescale your design afterwards.

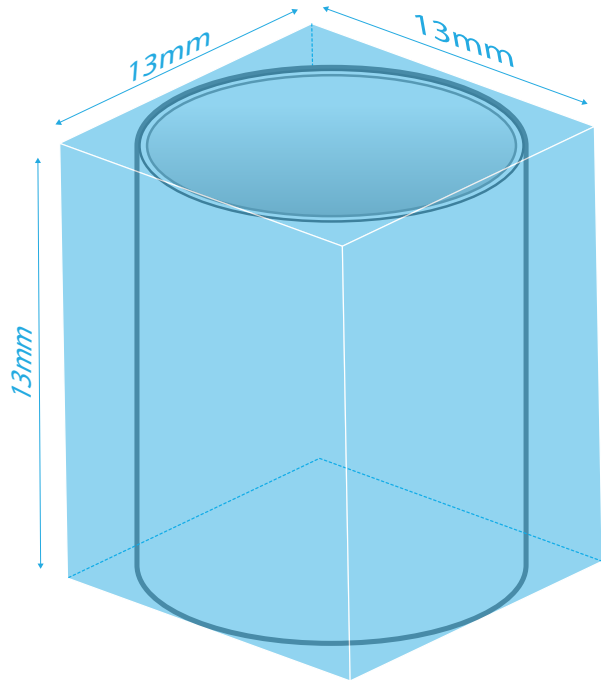

A cube of 13mm or 5.12 inches is the maximum size that your lampshade can be.

TIP Important! Designing within the bounding boxes is obligatory and designs which go out of bounds will be rejected..

Example

To help you design your lampshade, we have added an example to one of the layers. You can use it as a template or as a reference. The choice is yours.

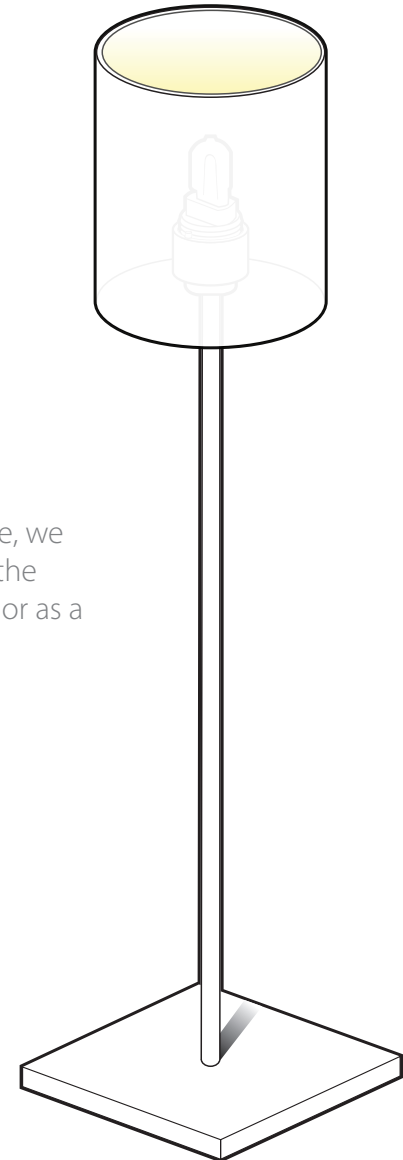

Step 2 - Lamp fitting

The second step is all about making sure your shade fits the lamp base. We have inserted an item called a lamp fitting in the design kit.

Fitting ring

We make use of a standard component to attach the shade to the base. This standard component will be inserted and glued to the lamp fitting (blue) by us. It is important for you, as the designer, to be aware of this and make use of this blue part in your design.

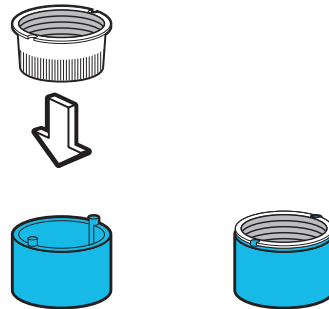

Securing

Once the fitting ring is attached to your lampshade, we can use the thread to secure it to the base.

By turning the shade counterclockwise the shade will be attached. To release it, you turn the shade clockwise.

TIP You need to find a way to firmly attach this lamp fitting to the shade. You can see a few examples how to do that below.

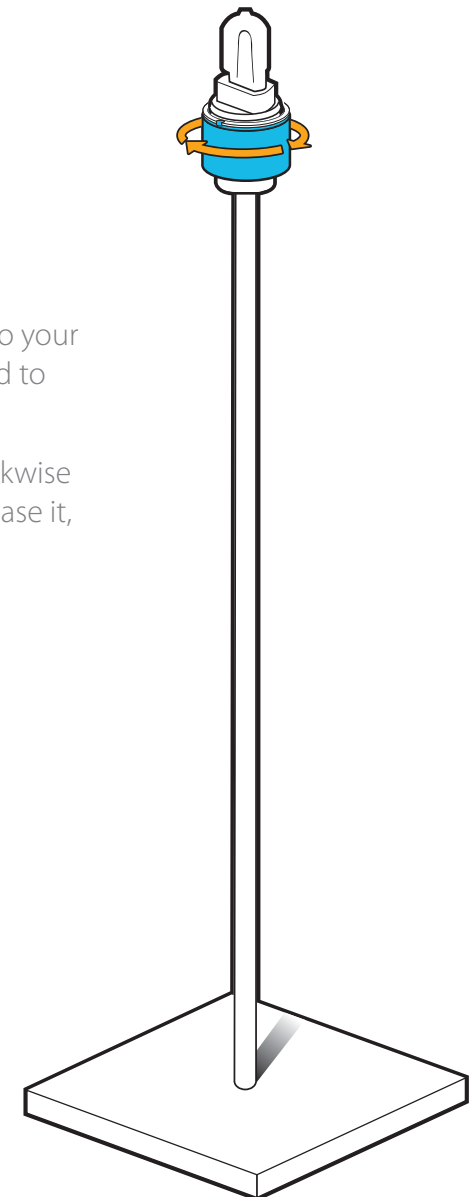

Step 3 - Safety

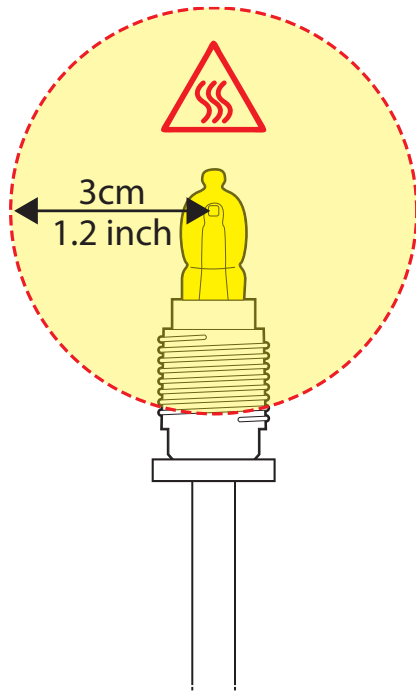

9

Safety

Since we're dealing with electricity, you have to make sure to include a spherical zone around the light bulb of $\varnothing 6$ cm / $\varnothing 2.4$ inches. This zone needs to remain completely open (hollow); it cannot contain any material. The starter kit contains a $\varnothing 6$ cm / $\varnothing 2.4$ inch sphere to perform this safety check. Place the sphere inside your lamp shade and make sure they don't intersect.

Airflow

Include an opening for the cooling of your lamp by allowing airflow. When you have ordered and uploaded your table lamp, we also do this safety check ourselves. This way we can deliver the safest product possible.

TIP

You should hide the light bulb in your lamp design. Not just for aesthetic reasons, but because the light produced can be pretty bright.

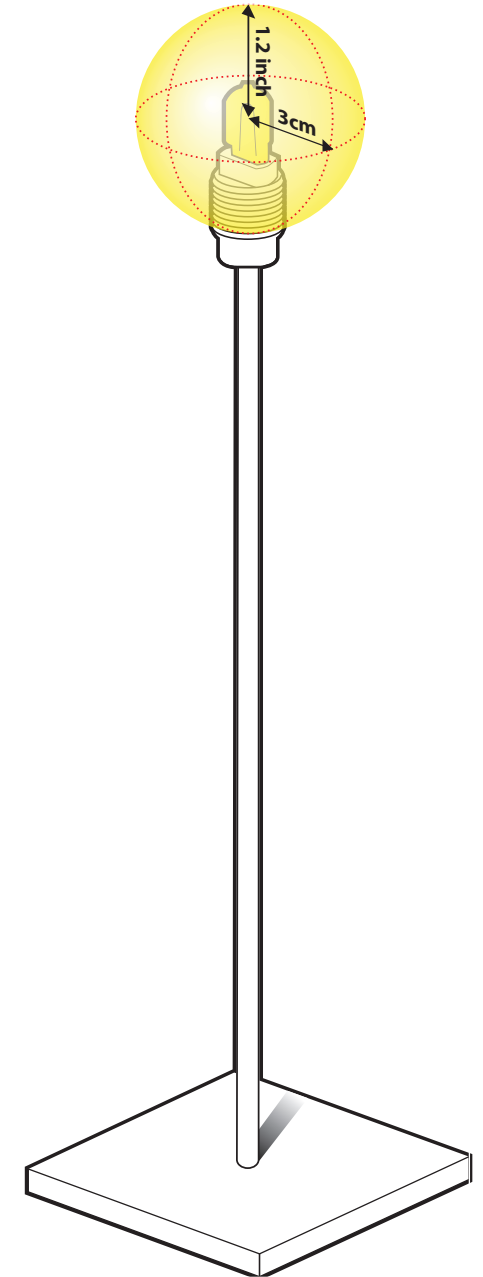

Step 4 - Checklist

Design guide

Check the general design rules for polyamide on our [webpage](#).

Go over the following items to verify whether your design is ready for uploading.

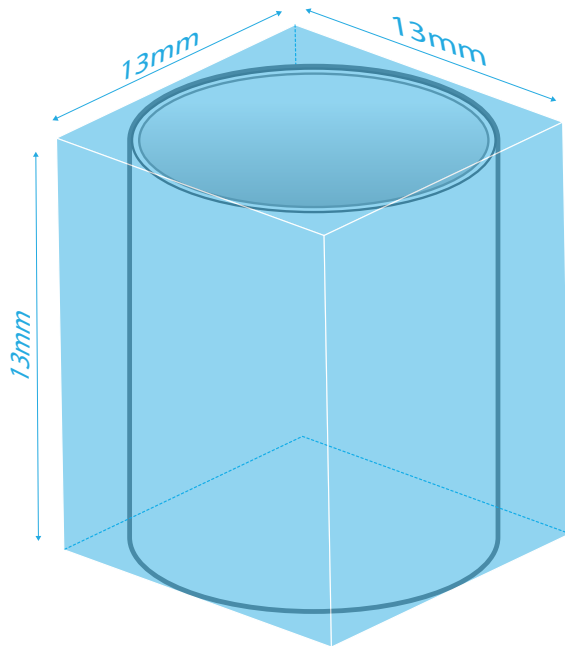

Building volume

Make sure your design fits inside of the building volume. If your model is too big, rescale, but make sure you don't lose too much wall thickness by doing so.

Wall thickness

Check the wall thicknesses. The walls of your model need to be at least 0.8/1 mm thick and on-surface details or imprints can be 0.4 to 0.5 mm. Ideally the wall thickness varies between 1.5 and 3 mm.

Material

Models in polyamide are constructed from a white, very fine, granular powder. The result is a strong, somewhat flexible material that can take small impacts and resist some pressure while being bent. The surface has a sandy, granular look, and is slightly porous.

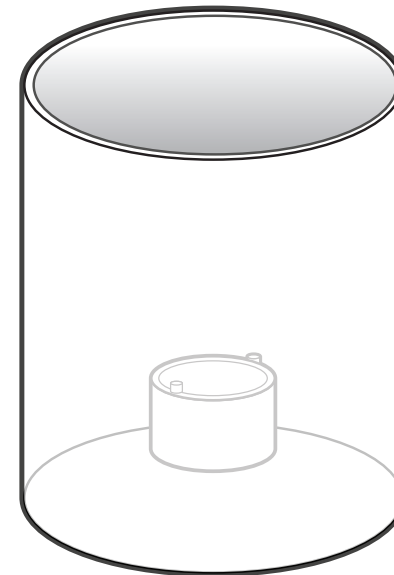

Content upload

Delete the references before uploading. Keep the lamp fitting in place in your design.

Step 5 - Upload

Upload

In order to have your design to be recognized as a table lamp you need to upload via the [table lamp page](#).

Once you have selected your file and pressed open, your file will be uploaded to our 3D print lab.

Preview

When the upload is complete, a preview will be generated. This way, you can see if the upload was done correctly.

Material

The material will be automatically selected since we only offer the table lamp shade in Polyamide. Choosing another material isn't possible.

Color

The color is limited to white. Selecting another color is not possible.

Checkout

If you are happy with everything, you can complete the order by pressing the checkout button. You'll be able to select the kind of plug you would like to receive.

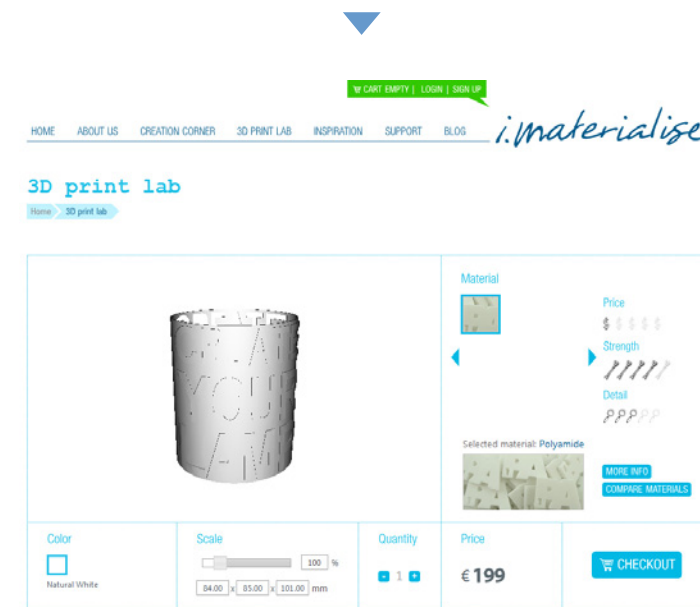
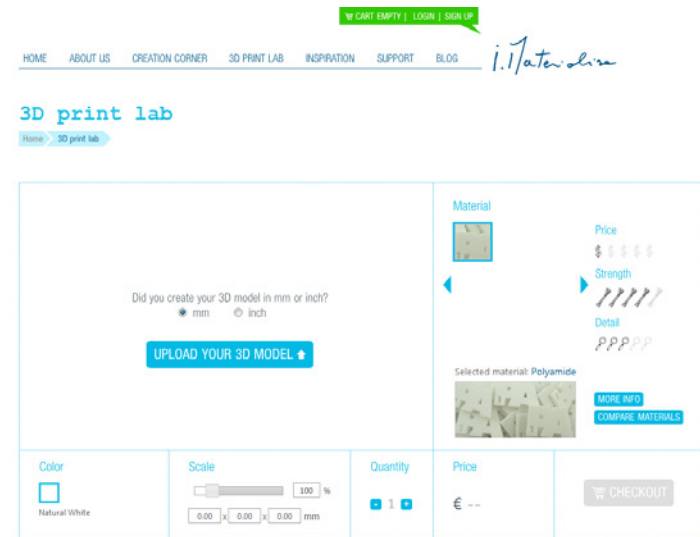

Example: Doorhandle by Hans Palacios



Design by Hans Palacios

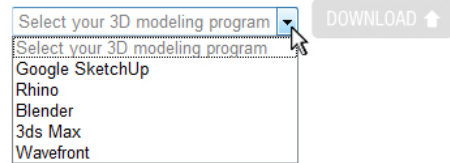

1 Hans designed a shade for a table lamp and would like to have a real life model of it. He downloads the i.materialise table lamp kit. He selects Google SketchUp..

2 Hans uses the different layers and references to adjust his design to the building volume, check the safety zone and attach of the fitting.

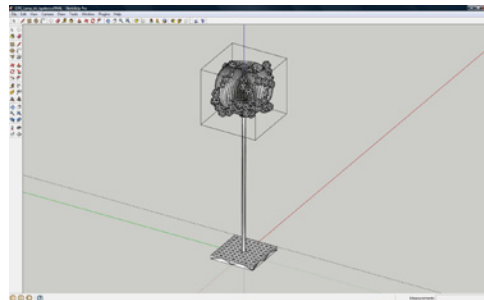

5 When the model is uploaded on the i.materialise website, Hans proceeds through the necessary steps and orders his lamp. Hans receives his 3D printed shade and metal base in mail. The lamp looks awesome, and is exactly how he pictured it!

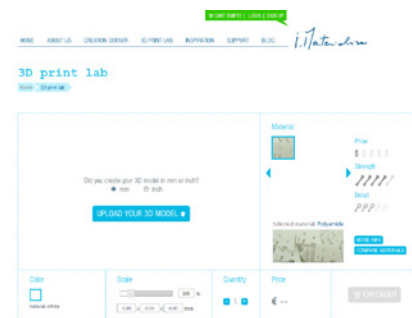

3 Once he is happy with the model, he presses the upload button and selects his skp file. His file is quite big, so he visits some other websites while it uploads. The progress bar keeps him updated on it's status.

4 Once the model is uploaded, he presses the checkout button and selects the type of plug he wants to have it delivered with.

Enjoy your 3D printed lamp

i.materialise